

9

8

7

6

5

4

3

2

1

REV.	ECN.NO.	APPD.
A	EXXXXXXXXXX	yangguifeng

F

F

E

E

D

D

C

C

B

B

A

A

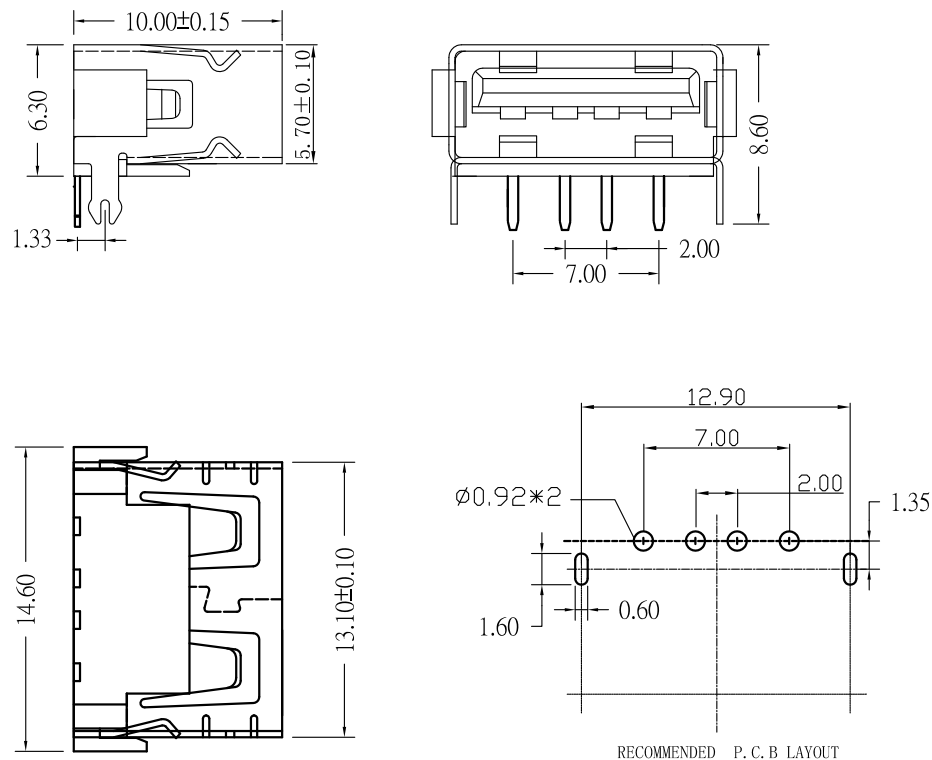

## NOTES:

## 1.MATERIAL:

1.1 Housing:thermoplastic plastics

1.2 terminals:Copper Alloy

Gold plated in contact area:

Tin plated in termination

Nickel Plated overall

1.3 Shell:Steel&amp;Copper Alloy

Nickel Plated overall

## 2.ELECTRICAL CHARACTERISTICS:

2.1 Rating Current :1.5 Ampere

2.2 Rating Voltage :30 V Max

2.3 Contact Resistance:30 Milli ohms

2.4 Insulation Resistance:1000 Mega ohms Min.

## 3.MECHANICAL CHARACTERISTICS:

3.1 Connector Mating force: 35N MAX(3.57Kgf)

3.2 Connector Unmating force:10N min(1.02Kgf)

3.3 Durability:1500Cycles.

## 4.ENVIRONMENT CHARACTERISTICS:

4.1 Operating temperature:-0°C to +50°C

4.2 Storage temperature:-20°C to +60°C

U221-511X-XXX0X7

1: 铁壳镀镍  
1: 吸塑盒  
G: 半金 G/Fu”  
1: 黑色  
6: LCP

TOLERANCE UNLESS OTHERWISE SPECIFIED		HLW 深圳市华联威电子科技有限公司 HUA LIAN WEI TECHNOLOGY ELECTRONICS CO;LTD.				
.XXX ±0.10	.X' ±3'	APPROVED	PART NAME: USB AF短体长度10.0高度6.3无卷边			
.XX ±0.20	.XX' ±2'	CHECKED	PART No: U221-5111-G61017			C
.X ±0.30		DRAWN	yangguifeng	PROJECTION:	UNIT:	SCALE
		DATE	2021.12.01		mm	1:1
					SHEET	REV.
					1 OF 1	A

9

8

7

6

5

4

3

2

1